

# **Incorporating uncertainty in CAD systems**

## **Development of XML Schema**

---

**05/03/2002**

**Jitesh H Panchal**

**Michael Carone**

**Injoong Kim**

Engineering Information Systems Lab, [eislabs.gatech.edu](http://eislabs.gatech.edu)

## ■ Geometry Uncertainty of Part

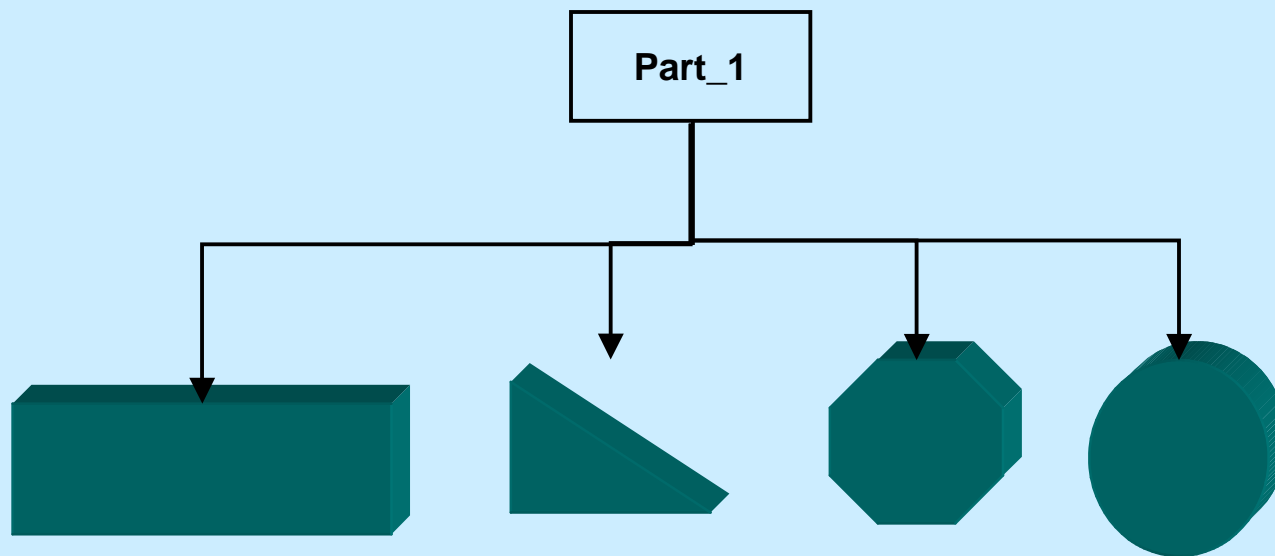

# ■ Dimensional Uncertainty of Part

## (1) Discrete Uncertainty

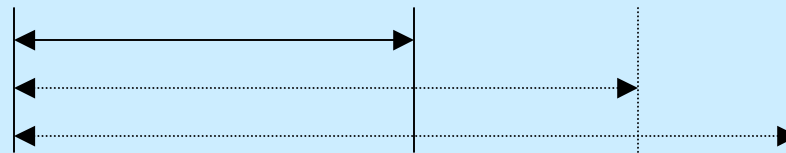

## (2) Uniform Uncertainty

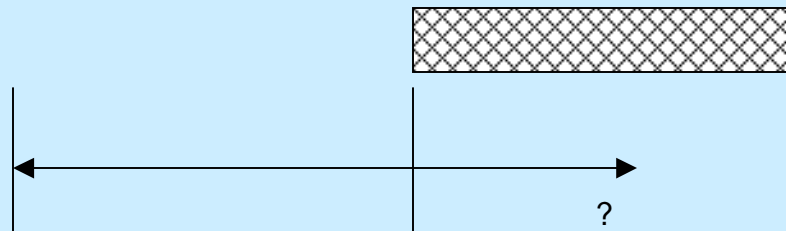

## (3) Distributed Uncertainty

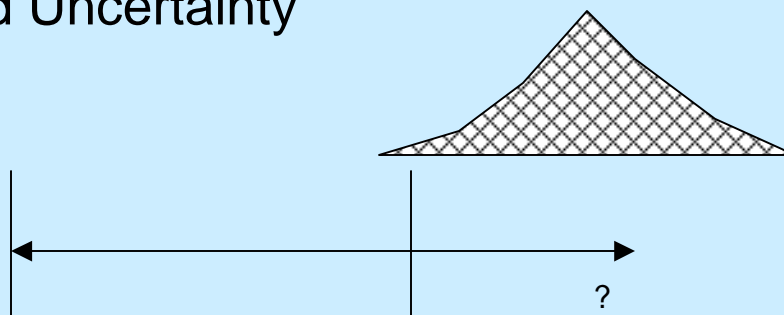

## ■ XML Schema for part

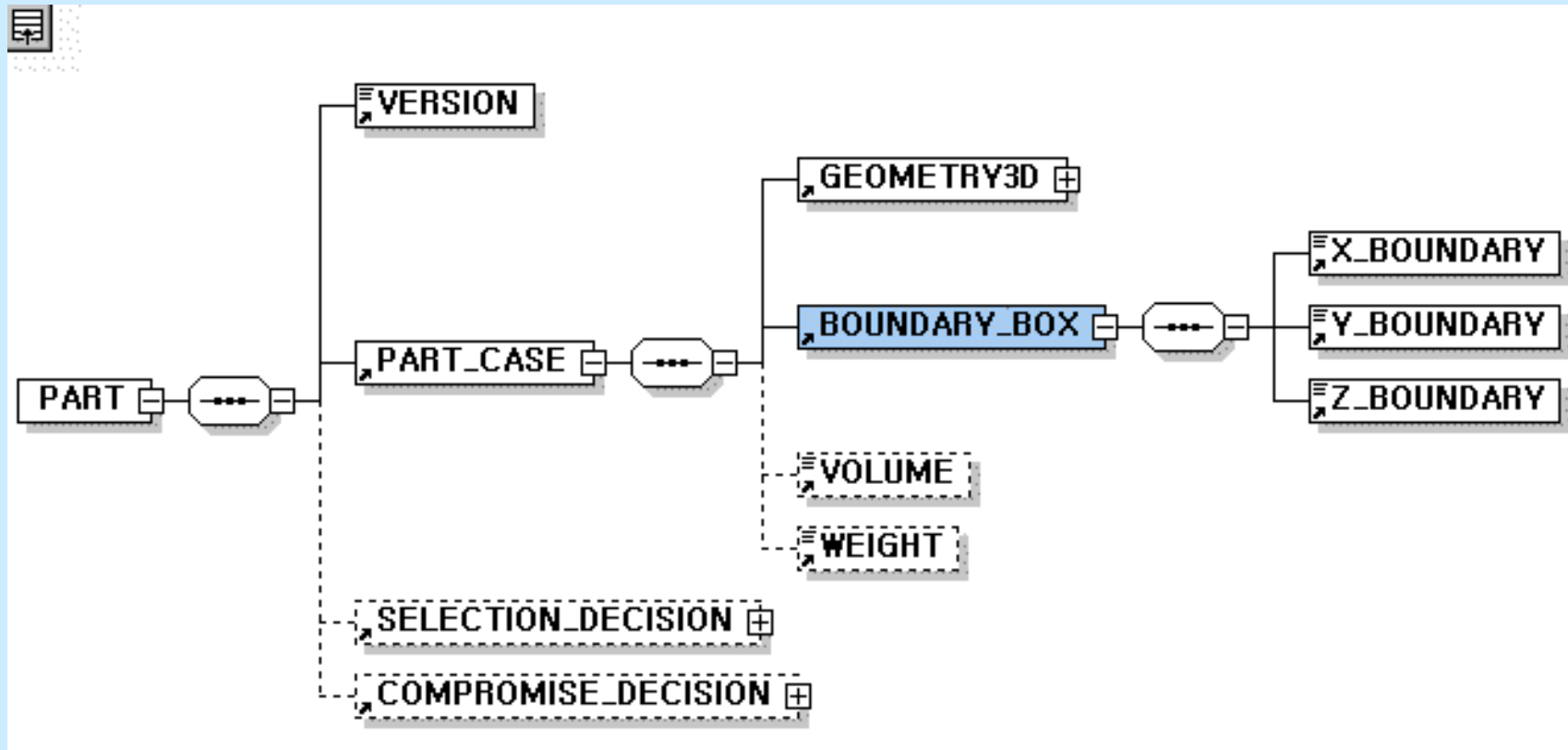

# XML Schema for geometry from Design XML

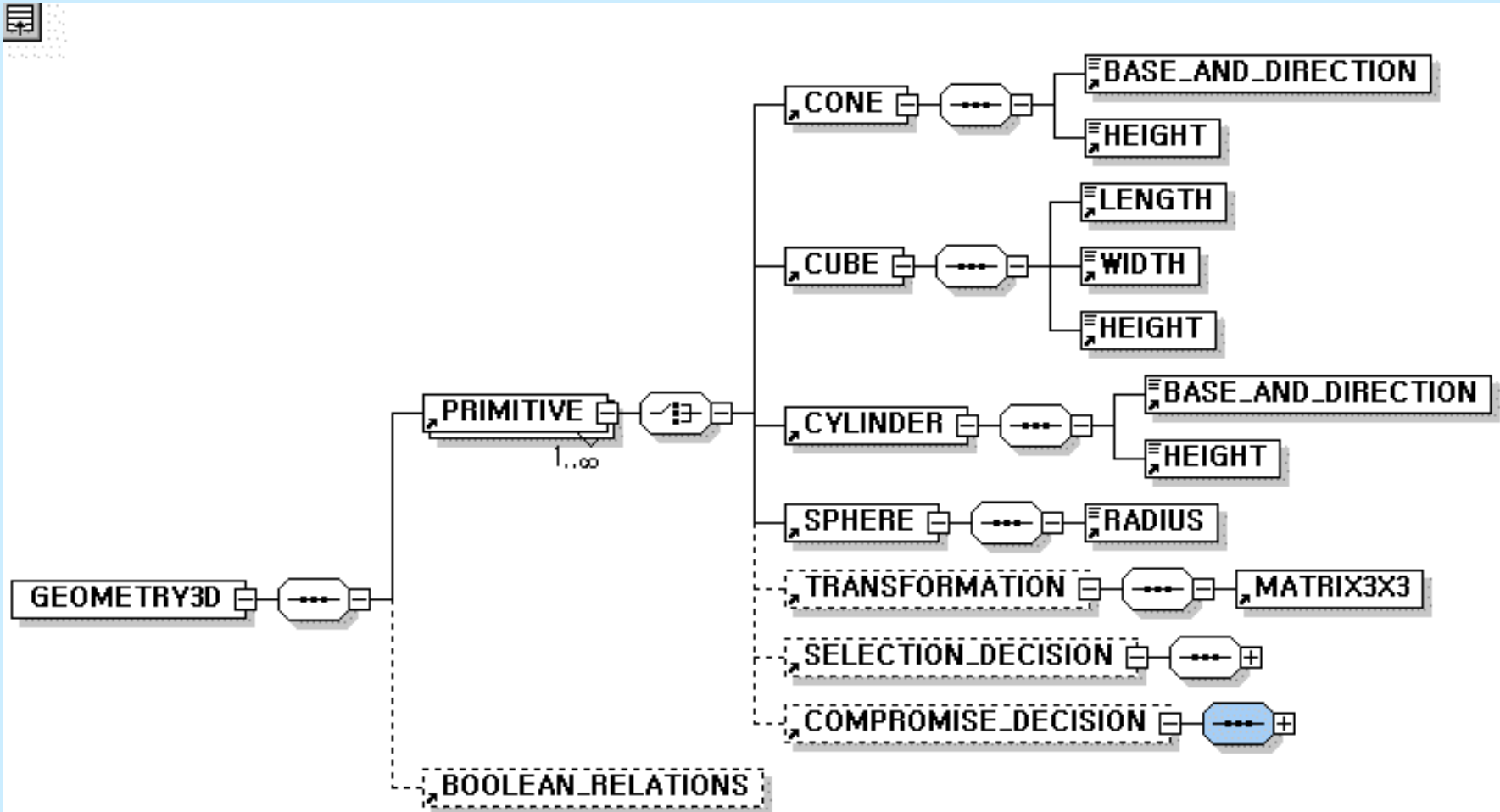

# ■ Boundary Box Concept for Assembly

(1) Boundary Box



(2) Alternative way : Developing Interfaces

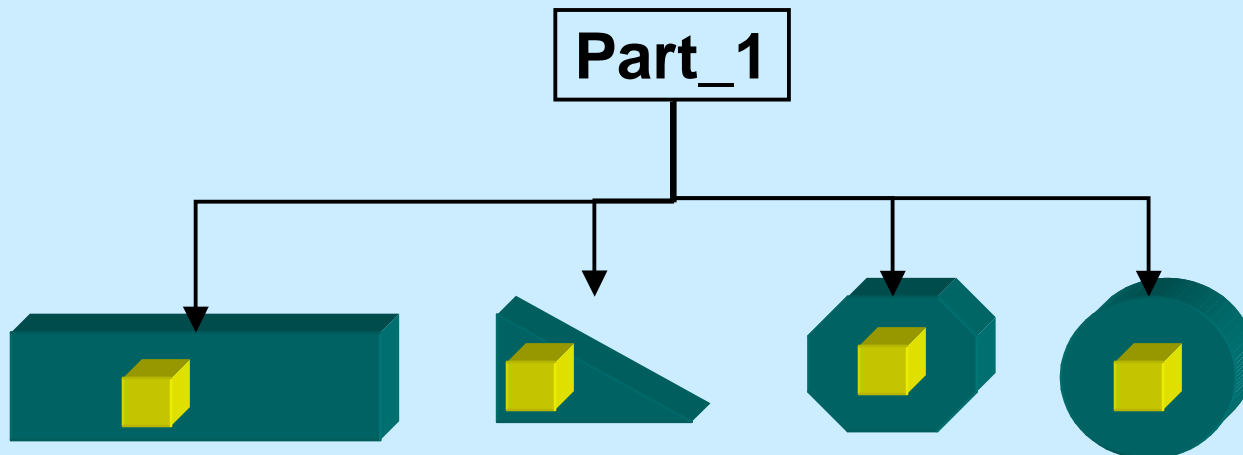

# ■ Mating Cases between Two Parts

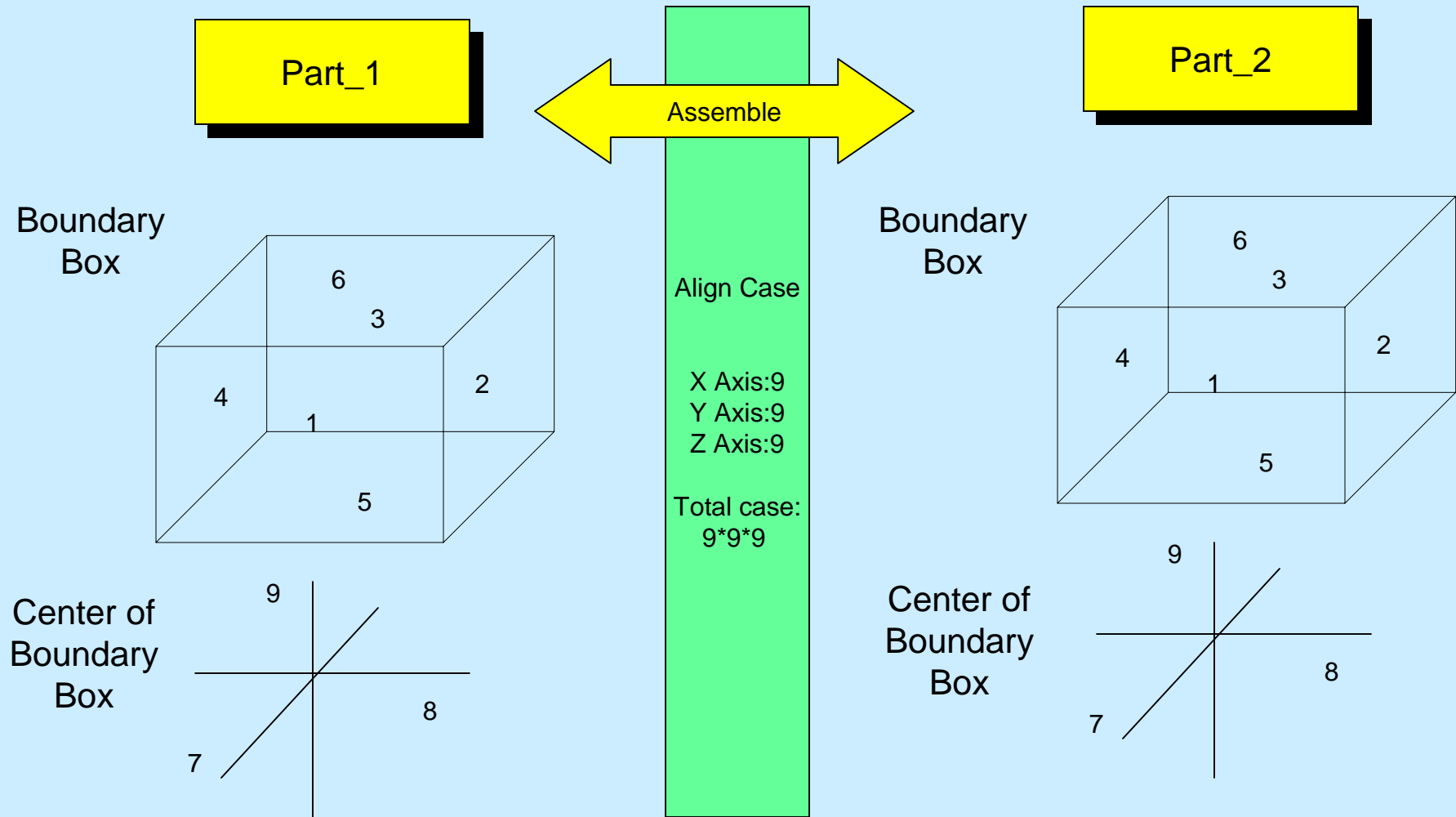

## ■ Simplified Assembly Tree

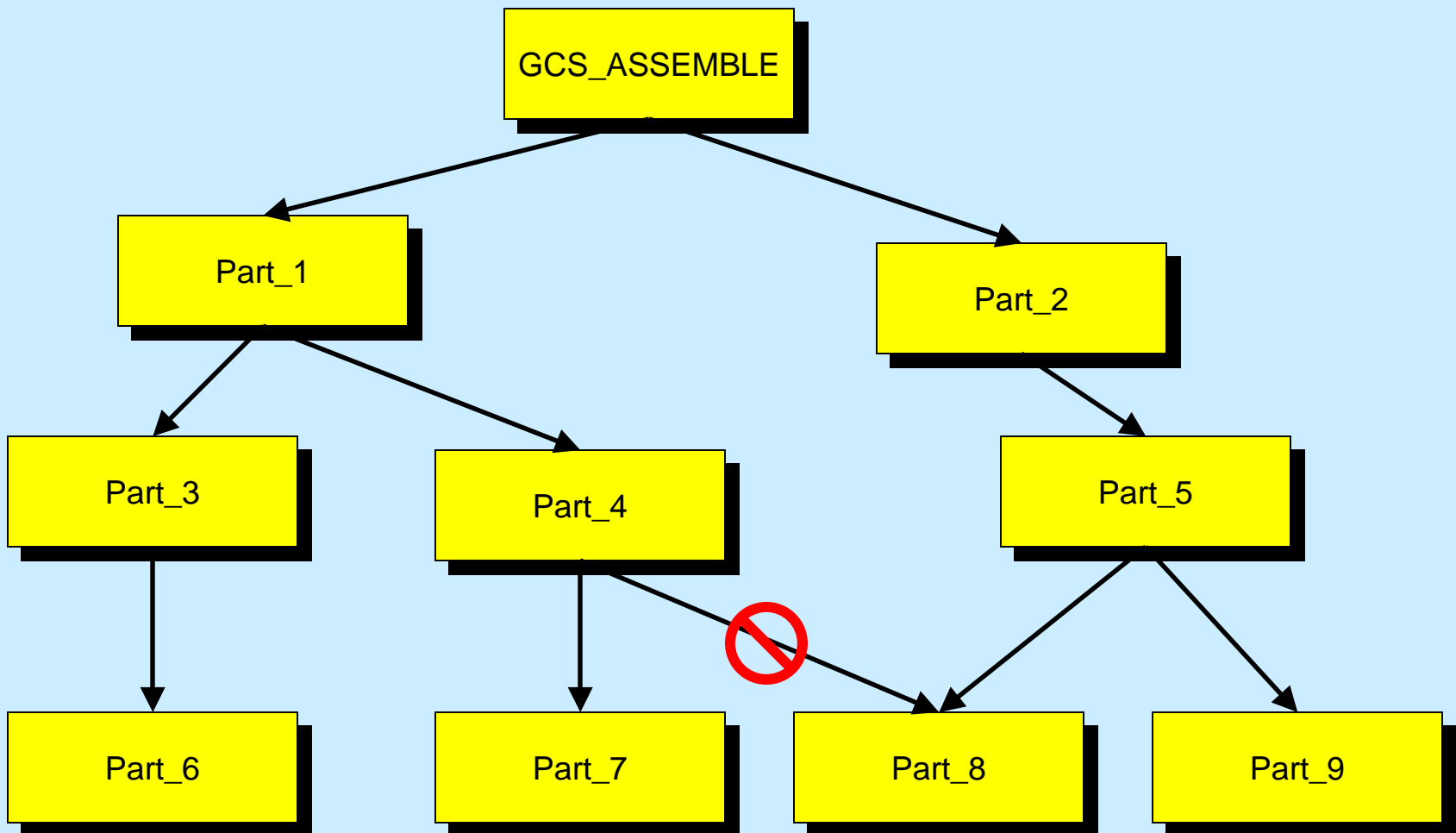

# ■ Propagation of Uncertainty of Parts to Assembly

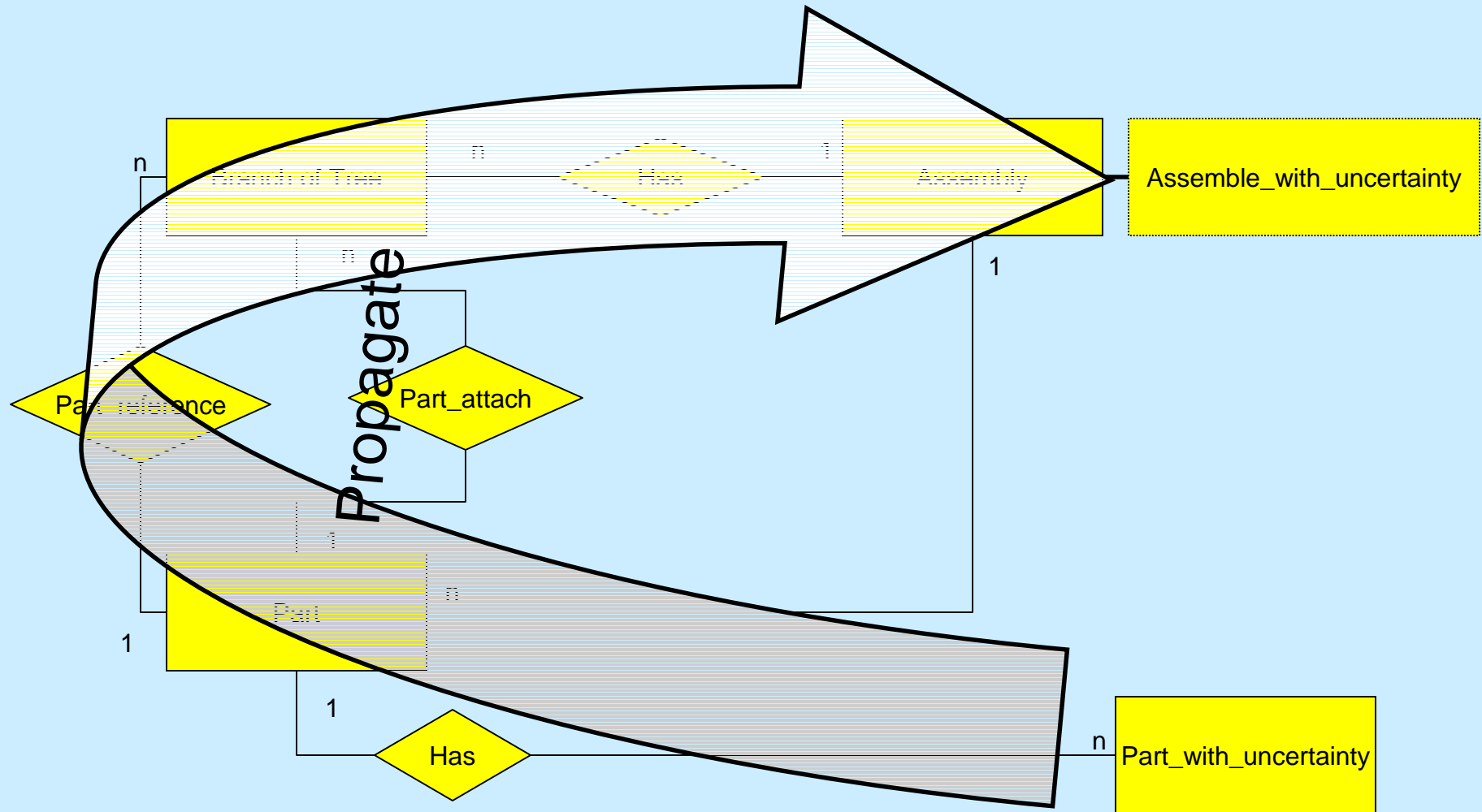

# XML Schema for Assembly

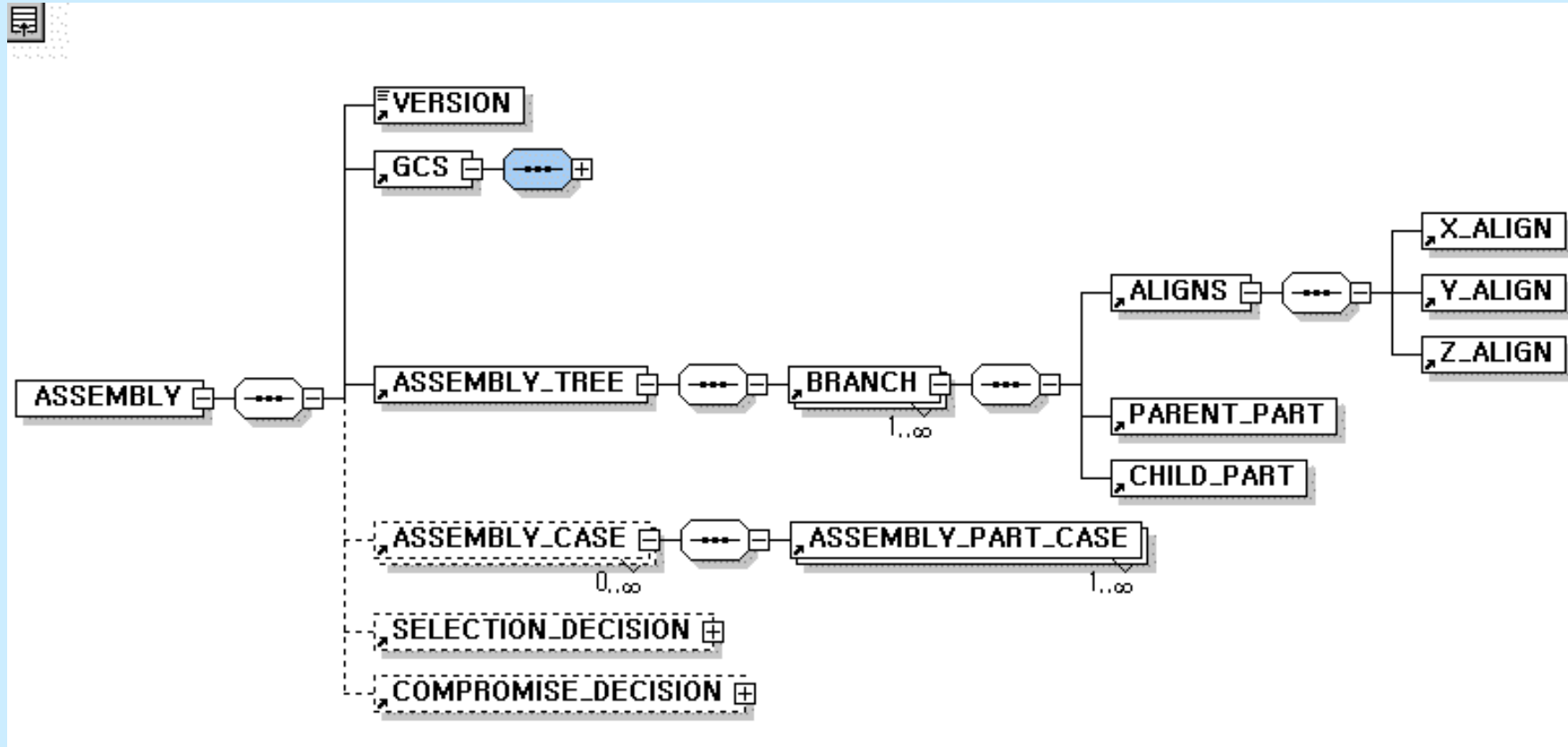

# ■ Evaluation

## (1) Selection

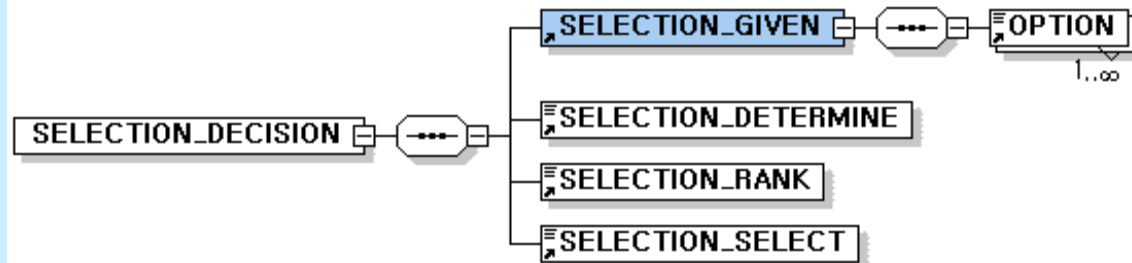

## (2) Compromise

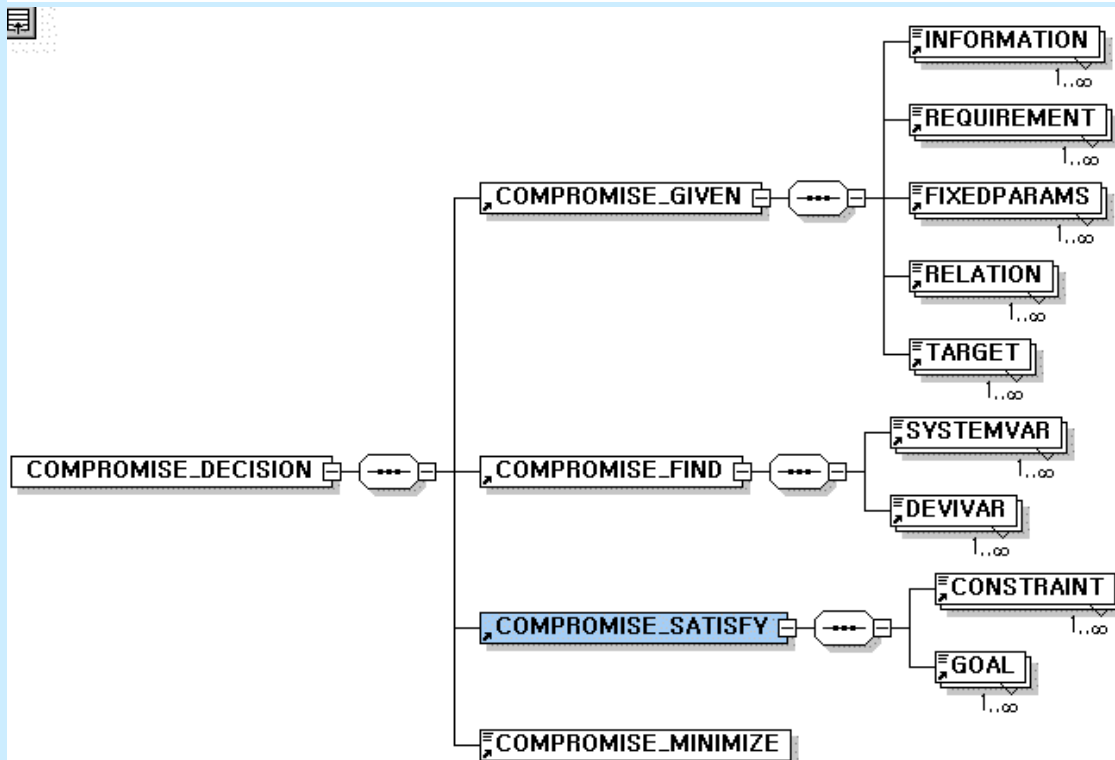

# XML Schema for Design with Uncertainty

